

Get a Sure Grip

with exact part length control

Hardinge combines Sure-Grip® parallel gripping technology, Dead-Length® exact part length control and a wide gripping range into one collet chuck to increase your productivity.

The four-split collet head is closed in a true parallel fashion for maximum gripping and instant centering. Collet heads have a $\pm .020$ " gripping range to accommodate bar stock or piece part variation.

The Hardinge Dead-Length® design offers exact part length control utilizing a nose-cap, and including a non-stick feature for instant, repetitive collet opening.

The OD Sure-Grip® Collet Adaptation Chuck fits all brand machines with an A2-5, A2-6 or A2-8 spindle nose. The Dead-Length® gripping feature makes this collet chuck ideal for twin-spindle applications eliminating drive fault situations that could be caused by collet pullback.

Patent No. US 6726211

Renderings shown in color to emphasize components.



OD Sure-Grip® Collet Chuck

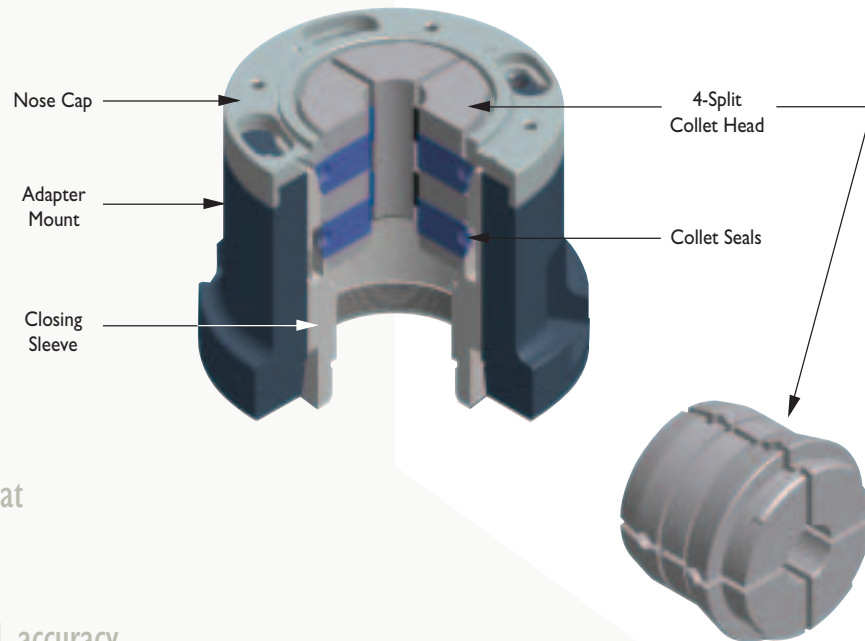

No loss of grip force at high rpm

Maintain precision and accuracy

Compact design offers large work envelope

Hardinge combines all the best technology and features to introduce the new OD Sure-Grip® Collet Adaptation Chuck.

Make your job easier while increasing productivity with these Hardinge features:

- Patented Sure-Grip® parallel gripping (no loss of grip force at high rpm)
- Dead-Length® exact part length control built in
- $\pm .020$ " gripping range to accommodate bar stock or piece part variation
- Compact design offers large work envelope to accommodate long workpieces
- Non-stick design for instant, repetitive collet opening
- Quick-change configuration

Compare these features to the chuck or adapter that you're currently using.

Expect more from your workholding. Maintain maximum grip force at high rpm, put out parts that meet or exceed specs, increase your job capabilities and eliminate aggravations that slow down your work. Call Hardinge today for more information on this system.

The Hardinge OD Sure-Grip® Collet Adaptation Chuck fits most brand machines with an A2-5, A2-6 or A2-8 spindle nose.

OD SG42 A2-5
OD SG42 A2-6
OD SG65 A2-6
OD SG65 A2-8
OD SG90 A2-6
OD SG90 A2-8

Hardinge Inc. One Hardinge Drive | P.O. Box 1507 | Elmira, New York 14902-1507 USA

USA: 800-843-8801 | Canada: 800-468-5946 | Fax: 607-734-3886

To Order Online: www.hardingetooling.com | Corporate Homepage: www.hardinge.com | E-mail: info@hardingetooling.com